

<http://www.oceanmanorhouse.com/paintremover.html>

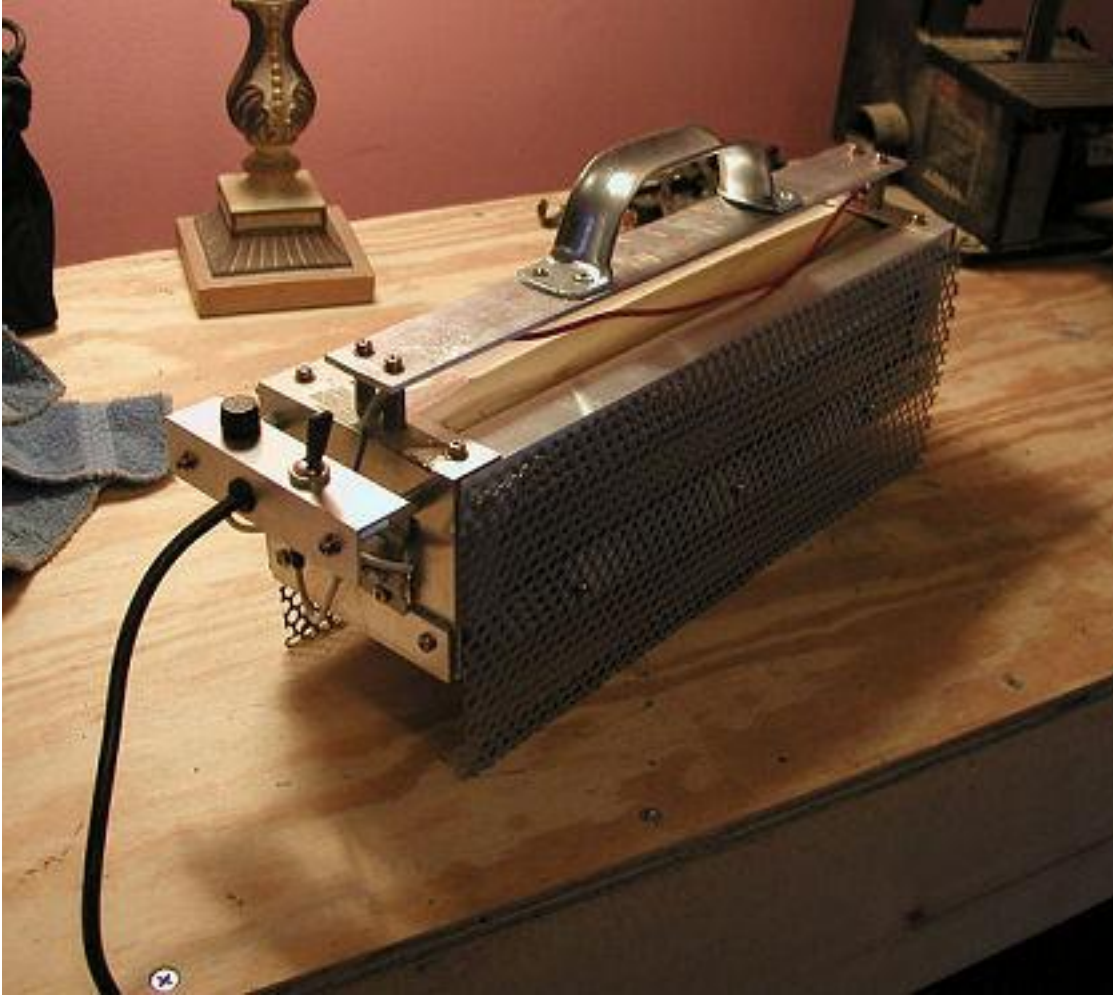

Construction

The first step was to disassemble a perfectly fine and working order quartz heater. The unit we had was a Lakewood HQT307, apparently a newer model, still available at Amazon, shown below. Once disassembled, I could see if there was any specialized circuitry involved in making the thing run. Turns out there is none, which was the final green light.



Opening the case. Of course, the power is unplugged...



Below is a picture of the inside of the unit. The wiring simple. House voltage essentially is dropped across the quartz rods in parallel...



The goal was to remove the rods from the unit without damaging them. I carefully cut tie wraps and unscrewed the part holding the fan and knobs. The image below shows the point of no return; the magic moment when the heater is either destined for glory, or to be hauled out with the trash next week...



The next image shows how the rods are held in the unit. We are looking from the "back"; the rods are behind the reflectors with the ends poking out the left. There is a few inches of space between the rods in this heater. My other Lakewood has much larger rods spaced very close together. The rod on the top of the image still has a metal bracket holding the cap in place. There is a same bracket at the other end of the rod. Now it's important to know a bit about the rods themselves. A quartz rod in these heaters is not a solid rod, it's hollow. Running through the center of the rod is a metal spring. Affixed to the the spring on each end is a porcelain cap. The porcelain cap is not secured to the quartz rod itself, the caps are held over the ends of the quartz rod by the tension of the spring which wants to pull the caps inwards. If you hold a quartz rod in your hands you can gently pull the caps apart and see the spring start to stretch. The spring connects to terminals through the caps to which wires are connected. Electric current is run through the springs causing them to heat up, which causes the quartz to glow. The bottom rod has had its wire cut...



The following picture shows the reflector pan and the rods as removed from the heater. At this point I measured the length of the pan because I would have to re-create that same dimension in my IPR. It's really the only critical dimension there is. For this heater model and these rods, it's 14.5 inches...



Now it was time to start constructing the box for the new IPR. I chose to use 1/8 inch angle aluminum from Lowe's. It would be easy to cut, not too heavy, same material as heaters are made from, strong, etc. I did my work with a hacksaw, you can make a smarter cut with a metal blade on a cut-off saw. I smoothed the edges and burs with a table sander...



The following image shows the top of the box. 14.5 inches long, 4 inches wide. I wasn't too fixated on getting the holes for the four screws centered down to a hair. It really isn't that critical. What is critical is making sure that lock washers and flat washers are used. One doesn't want the thing to come apart during use. A proper mechanical connection of this sort uses a machine screw (I used 4mm screws), once the screw is put through both pieces, a flat washer is placed on the end of the screw and then a split washer or star washer is put over that. Then the nut goes on. With this method, the screw will never work free. All drill holes had their burrs removed. One can do so using a large drill bit (1/2" or bigger) in your hand. Wrap tape around the bit to keep the sharp edges from hurting your hands...



The "legs" of the IPR were next. I chose to make them 3.5 inches long. More screws, more washers, more nuts. Once the four legs were done I used 1"x1/8" aluminum (from Lowe's) for the "skirt". The image below shows me ready to cut it to length on the left. I ran the skirt "around" the base of the legs. In all it made a very strong box. It could support my weight without damage...

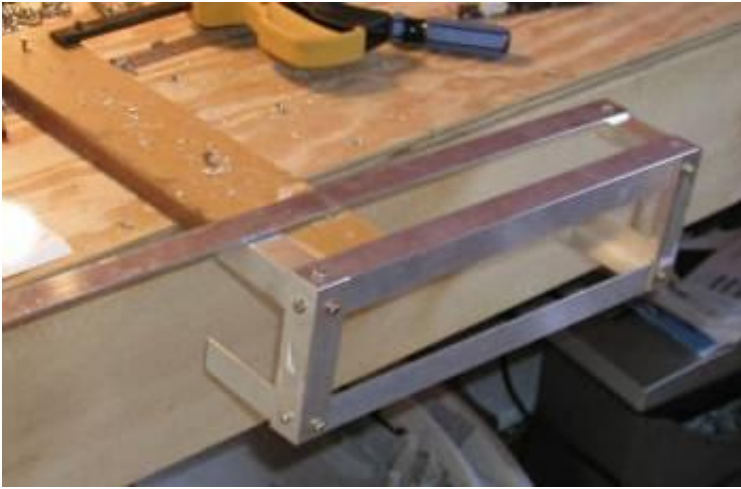

Here's an image of the IPR box frame completed:

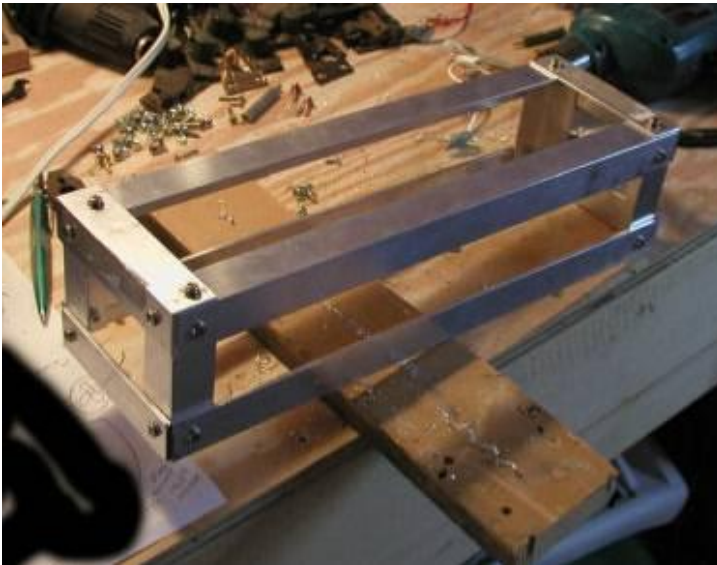

Next step was to add a reflector to the box. I used a piece of vent pipe from Lowe's. The inside has a gold reflective coating. It is very flexible and easily cut with tin snips. It was a few bucks. 4" vent or something, from the dryer vent isle. I cut a square from it size enough to make a nice reflector for the box.



These images show the reflector placed into the box frame. Two screws on each side of the frame double up on their duty in order to secure the reflector to the frame...

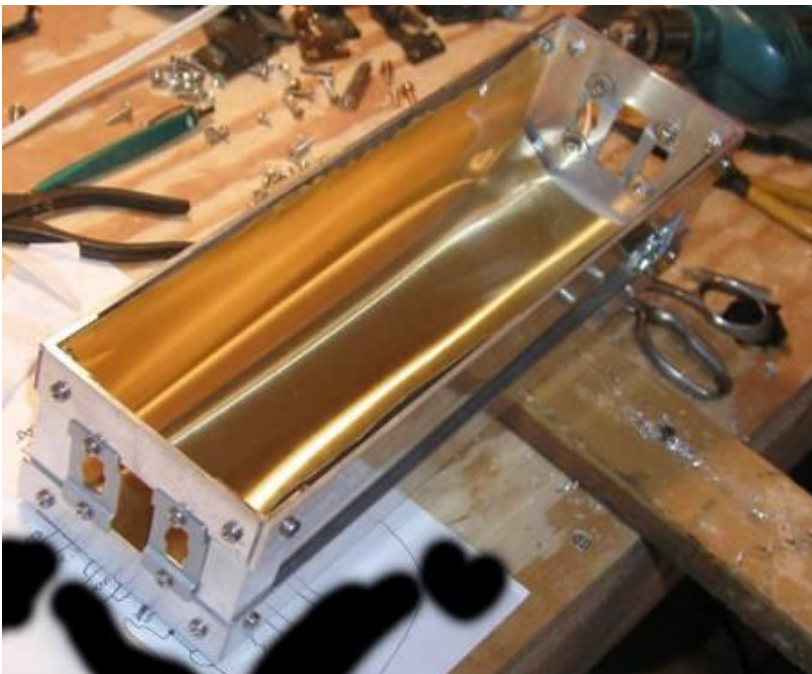

Waste not want not. Might as well use the tin snips to cut those "height adjusters" from the quartz heater's face shield. Of course as installed here, mine aren't readily adjustable without a screw driver, but it turned out not to be a big deal. Screws that hold the "Adjusters" on also hold more places of the reflector:



A 1.5"x1/8" piece of aluminum cut to length serves as a platform for a handle (yup, all from Lowe's). The platform is raised on 1 inch stand-offs (not from Lowe's, I scrounged 'em). A metal handle is not a wise idea, but I already bought it, more on that later though. It is starting to look like an IPR !!!!

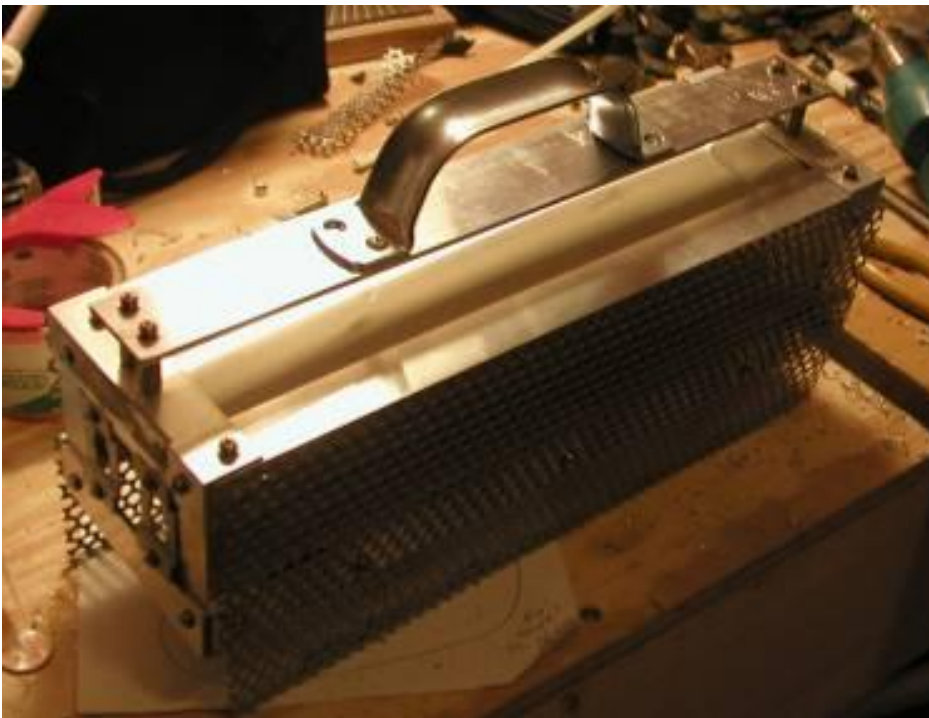

Here's an important picture, it shows the rod holders in place. They are taken from the quartz heater. There are four of them, all alike. The porcelain caps on the ends of the quartz rods, simply sit in the holes. Here's an analogy to explain it: Imagine a rolling pin (the kind with handles). Imagine it sitting on a table. You take each of your hands and make an O with your index finger and thumb. Take the O's, place them over the handles of the rolling pin and lift. This is the same way the rods are supported. The metal holders here are the O's, the quartz rod is the pin itself, and the handles of the rolling pin are the porcelain caps. A good thing here is that these metal holders could be flipped over if the box was a bit too short. They could also be installed on the inner side of the box too, so there's four ways on each end to try in case you get the length wrong. The holders are affixed with screws on which large washers hold the edge of the metal strapping. This had the side benefit of making the position of the rods somewhat adjustable. I didn't plan it as a design feature, it just worked out. I was going to sheath the ends and cut holes for the rods, glad I didn't , un-necessary. Once installed, the rods should have some play, about an eight inch back and forth. You don't want to stress the rods, but you don't want them falling out of the holders either:

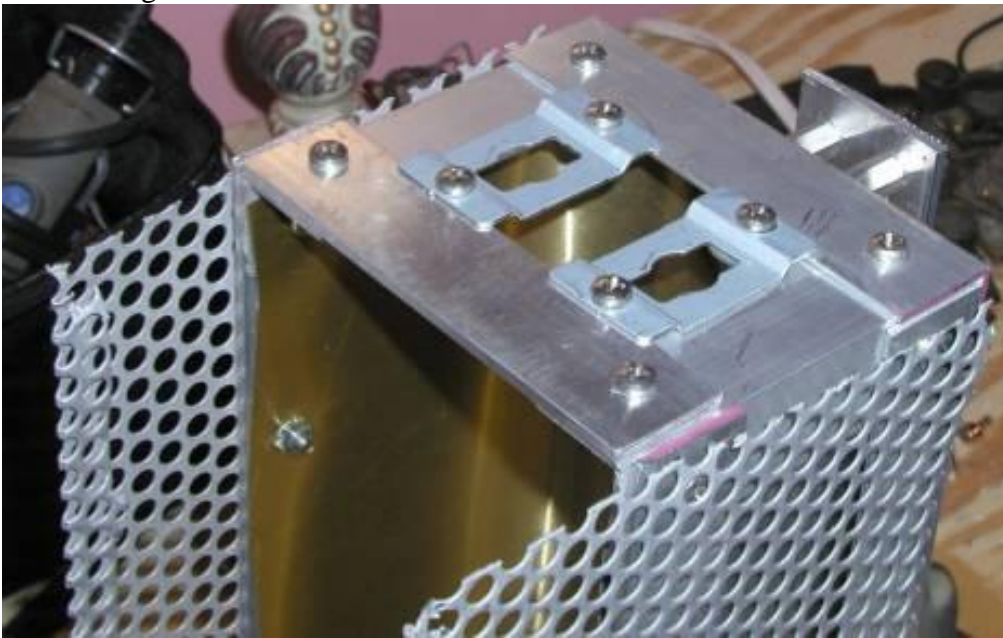

The following image shows the bracket for the soon-to-come power switch and fuse. I didn't want to affix that stuff to the box in case the box got really hot. So I stood it off on a few stand-offs with a piece of angle aluminum left over from making the frame. I didn't drill new holes in the frame for this, I removed the screws that were in the end of the frame and screwed the stand-offs in instead. The angle aluminum is oriented so the switch will be protected from casual contact from the top, and from the end where an errant scraper might come from.

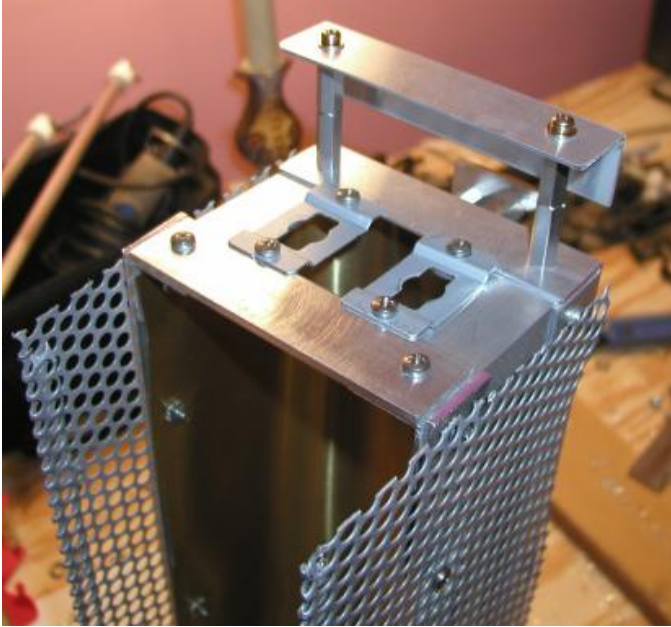

Below is another important shot. The rods must be treated delicately lest they break and the project delayed. A little caution is better than a trip down to Home Depot for another quartz heater. The image shows the used ring lugs being removed from the terminals. The needle nose pliers are holding the inner nut firm, while the socket screwdriver loosens the outer nut. The threads have LockTite on them so the pliers must be held firm. No pressure is put on the quartz behind. Never touch the quartz part of the rods with your bare fingers, there is evidence that oils from your skin can compromise their life span.



Here the rods have been installed. In order to do so, the metal holders at one end must be removed and the rod slid in from the end. Once an end of the rod is in place, the metal holders on the install end can be affixed over the rod. At that point the rods can be made parallel and a bit of free play in the rods can be insured.



Here the switch and the fuse and the power cord are installed onto the holder bracket. The switch is from Radio Shack. Make sure the switch is rated at least ten amps, 15 even better. The fuse holder I scrounged and the power cord I stole from a printer. It is important at this stage to know the difference between the neutral, hot, and ground wires from the power cord. I elected to run the hot line through the fuse and the switch, then to the ends of the rods at the same end of the unit. That way I wouldn't be running the hot lead all the way down the length of the unit. That way if the hot lead breaks free, it's only an inch or so long and won't flap around too far. The neutral lead I ran down to the other side of the quartz rods. The **MOST IMPORTANT** thing in the whole project is to connect the ground wire to the chassis itself. This gives some measure of protection in case the hot lead shorts to the chassis somehow, or if the quartz rod breaks and the springs short to the chassis, etc.



Here's my simple schematic. I re-used the wire from the heater, I figure it must be rated for heat in some regard. Connections to the quartz rods are via ring lugs crimped onto the wires. Connections to the switch and fuse are soldered although in retrospect that may not be so wise, I should replace them with quick disconnect lugs. Caution: your browser might size it down to fit the window:

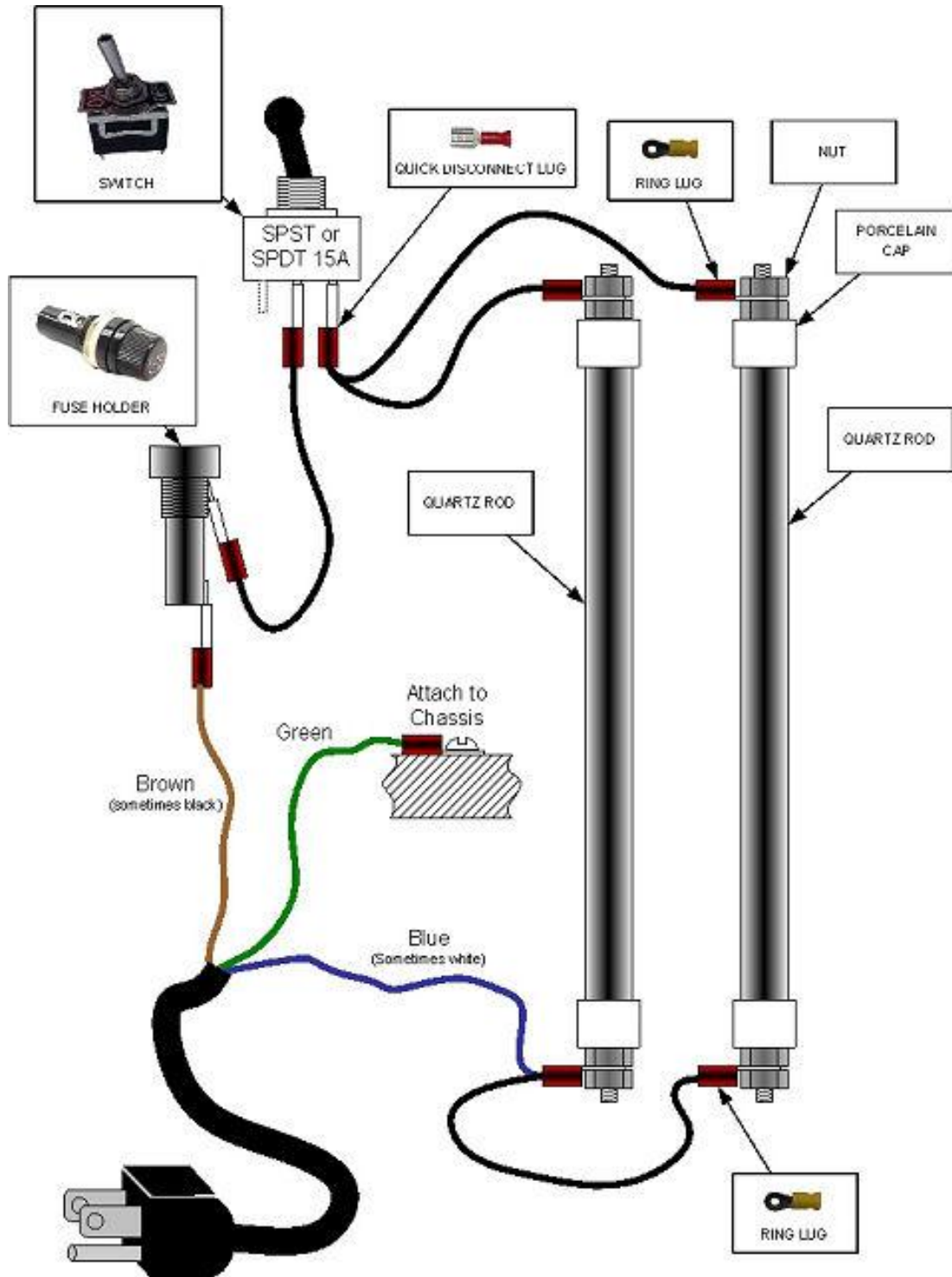

The image below shows the wiring close up. The power cord is run through small grommet (Lowe's) and tied in a knot behind. This keeps tension off the components when you yank the power cord while using it. As you can see, most importantly, the green ground wire is lugged to the chassis. The brown Hot lead from the power cord goes to the fuse then the switch. From the other side of the switch, Hot is distributed to the ends of the two rods. The blue Neutral wire runs to the other side of the unit and connects the two ends there. The fuse in the holder MUST be rated for at least 10 Amps, and make it a fast-blow fuse. A five amp fuse will simply blow.

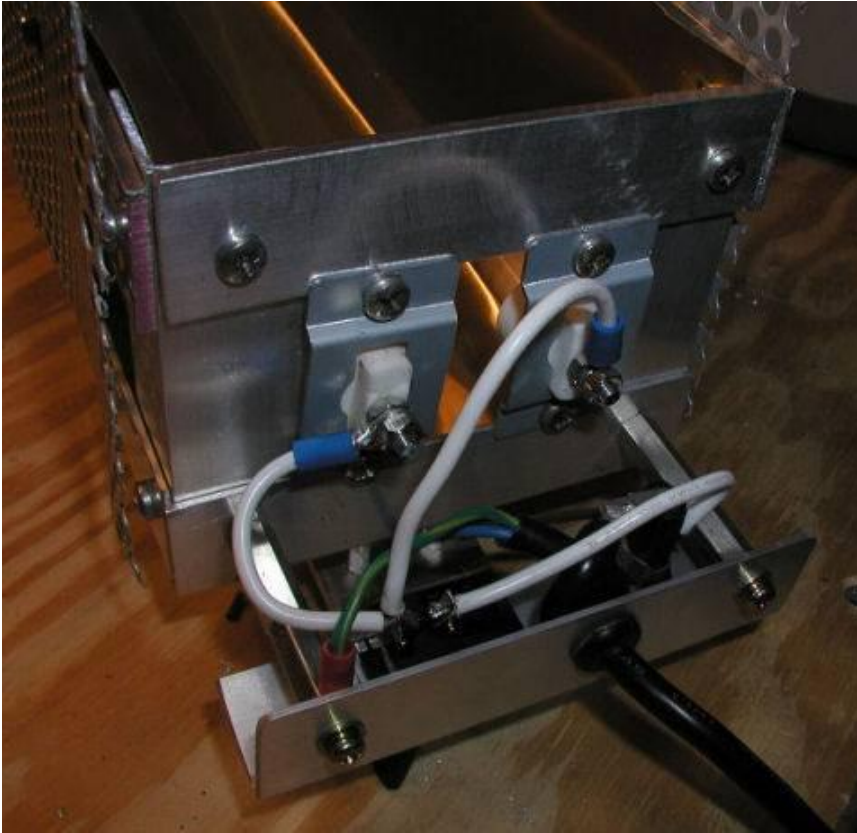

If one wires up the ground to the chassis as shown. That's a good thing, but if the house outlet your plugging this into is not wired correctly, then the safety measure is useless. If one were crazy and made one of these they would be very smart to test the AC outlet with an outlet tester to make sure the outlet is ground and wired correctly. You be surprised at how many outlets aren't. Of course, it goes without saying that if you use one of those three prong to two adapters, or an extension cord with no ground lead, the safety measure is useless. Plugging the unit into a GFCI outlet would help insure safety too.

Finally, here is the unit, ready for testing, more or less complete albeit some refinements perhaps required.

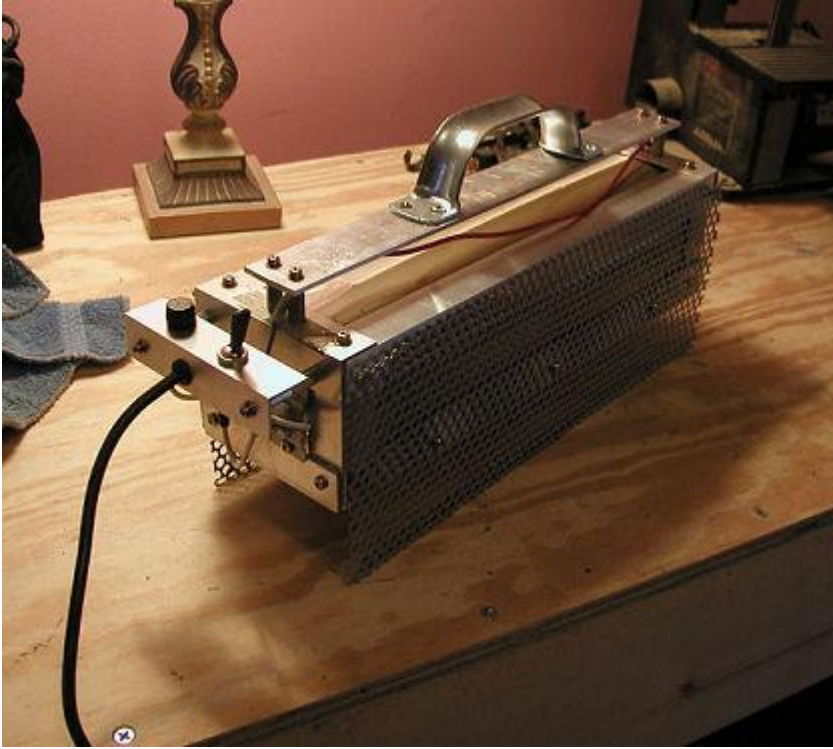

Here we go! Notice I'm wearing a glove, that is because I didn't know how hot the handle may get, and wanted to be safe in case all the other safety measures failed. Upon throwing the power switch the quartz rods made that telltale momentary buzz they usually do when a quartz heater is turned on. They started to glow and we were off and running. Using it like I imagined it should be used, I held it over a spot for 10-20 seconds. Lifting it up, the paint underneath had started to bubble and lift. The scraper took it off like hot cheese.



Here's a picture of the thing under power.

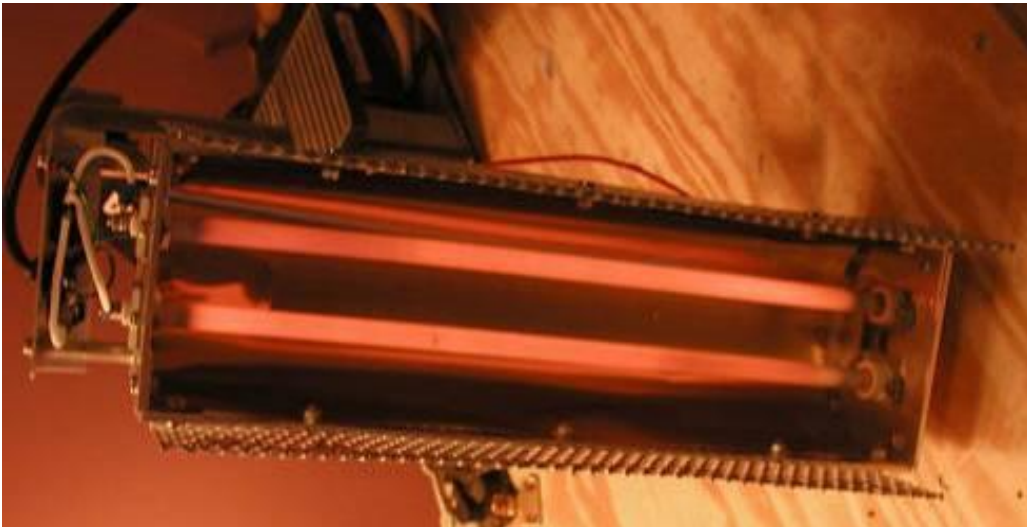

Performance/Notes

The thing seems to work exactly as it should. After about 20 minutes, the chassis was too hot to touch. I don't think it's an issue at this point. An ordinary quartz heater gets too hot to touch too, and it isn't a problem. The aluminum isn't going to melt and I doubt the rods will suffer, they're made for heat. What concerns me most is the switch area becoming too hot. The switch holder, sitting out on the standoffs seemed to stay cool much longer than the chassis itself. It wasn't until a good half hour went by that it was getting too hot to touch. This is something I'm thinking about now. I brought home some Teflon tubing and will encase the red wire running along the top in Teflon. This should protect it even more.

Takes off house paint... "no problemo:"





Conclusion

In all I consider it a success. I'm going to use the damn thing and tweak it for safety, keeping a mindful eye on respecting the discussed safety issues.

The Lakewood web site insinuates that replacement parts for the heaters can be bought there. So if I break a rod I won't go buy a whole new heater. I'm going to replace the metal handle for something non-conductive, mostly for psychological reasons.

I hope you enjoyed my little experiment. This page is somewhat preliminary and I will update as I learn and tinker.

Happy Restoring

Dave